

ELEVATED WORK PLATFORM HIRE

SPECIFICATION SHEET

SCISSOR LIFT

10m/26ft ELECTRIC

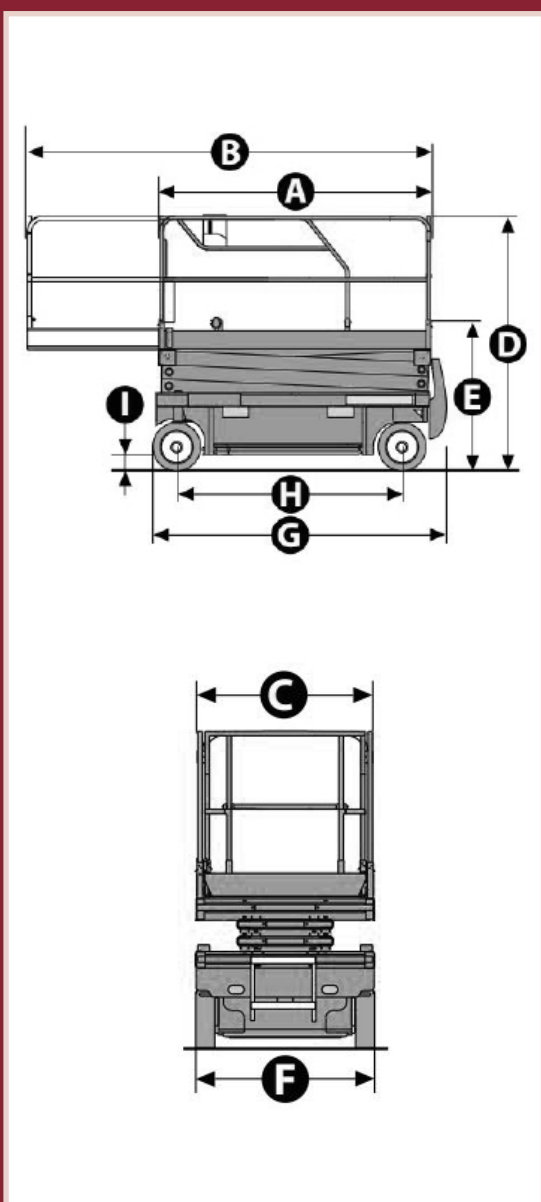

SPECIFICATIONS

MEASUREMENTS

Working height max	10.15 m
Platform height max	7.90 - 8.15 m (depending on model)
A Platform length - outside	2.31 m
B extended	3.23 m
C Platform width - outside	1.20 m
Roll-out platform extension	.92 m
D Height - stowed rails folded	2.26 m
	1.91 m
E Storage Height	1.40 m
G Length - stowed	2.49 m
Length - stowed extended	3.41 m
F Width	1.17- 1.20 m (depending on model)
H Wheelbase	1.86 m
I Ground clearance - centre	.13 m
-with pothole guards deployed	2.5 cm

PRODUCTIVITY

Lift capacity	450 kg
Drive speed - stowed	2.9 km/h
Drive speed - raised	0.8 km/h
Gradeability	23%
Turning radius - inside	zero
Turning radius - outside	2.5 m
Raise / lower speed	32 / 42 sec
Tyres - solid non-marking	15 x 5 in

POWER

Power source	24 V (4 6V 225 Ah batteries)
Hydraulic system capacity	25 L

WEIGHT

	2330 kg
--	---------

