

SPECIFICATION SHEET

3 2 f t D I E S E L

SCISSOR LIFT

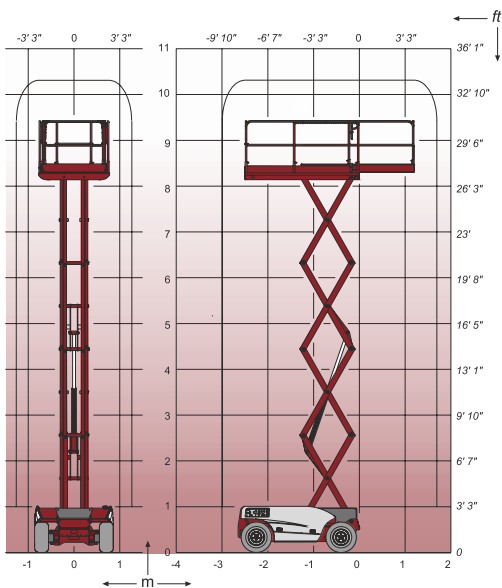

3 2 f t D I E S E L S C I S S O R - 1 2 D X

SPECIFICATIONS

	Compact© 10 DX		Compact© 12 DX	
Working height	10,2 m	33 ft 5 in	12.15 m	40 ft
Platform height	8,2 m	27 ft	10.15 m	33 ft 3 in
Platform capacity	565 kg	1,245 lb	450 kg	992 lb
Length	2,65 m - 8 ft 8 in			
Width	1,80 m - 6 ft			
Stowed height (guardrail)	2,37 m	7 ft 10 in	2,54 m	8 ft 4 in
Stowed height (platform)	1,5 m	4 ft 11 in	1,68 m	5 ft 6 in
Wheelbase	1,87 m - 6 ft 1 in			
Ground clearance	25 cm - 10 in			
Platform size	2,5 x 1,54 m - 8 ft 2 in x 5 ft 1 in			
Platform extension	1,2 m - 47 in			
Drive speed	0,8 / 5,5 km/h - 0,5 / 3,4 mph			
Outside turning radius	3.73 m - 12 ft 3 in			
Inside turning radius	1,45 m - 4 ft			
Lift / lower speed (s)	35 / 40 sec.		40 / 45 sec.	
Power source	18kW - 24.5 hp			
Gradeability	40%			
Brakes	Hydraulic			
Tyres (foam filled)	26 x 12-12			
Hydraulic tank	80 l - 17,6 gal			
Fuel tank	30 l - 6,60 gal			
Weight	3 330 kg	7300 lb	3 830 kg	8580 lb

AS1418.10

